

DESIGN NOTES

Telephone Ring-Tone Generation – Design Note 134

Dale Eagar

Requirements

When your telephone rings, exactly what is the phone company doing? This question comes up frequently, as it seems everyone is becoming a telephone company. Deregulation opens many new opportunities, but if you want to be the phone company your have to ring bells.

An Open-Architecture Ring-Tone Generator

Here is a design that you can own, tailor to your specific needs, layout on your circuit board and put on your bill of materials. Finally, you will be in control of the black magic (and high voltages) of ring-tone generation.

Not Your Standard Bench Supply

Ring-tone generation requires not one but two high voltages, 60VDC and -180VDC (this arises from the need to put 87V_{RMS} on -48VDC). Figure 1 details the switching power supply that delivers the volts needed to run the ring-tone circuit. This switcher can be powered from any voltage from 5V to 30V and shuts down when not in use. Figure 2 is the build diagram of the transformer used in the switching power supply.

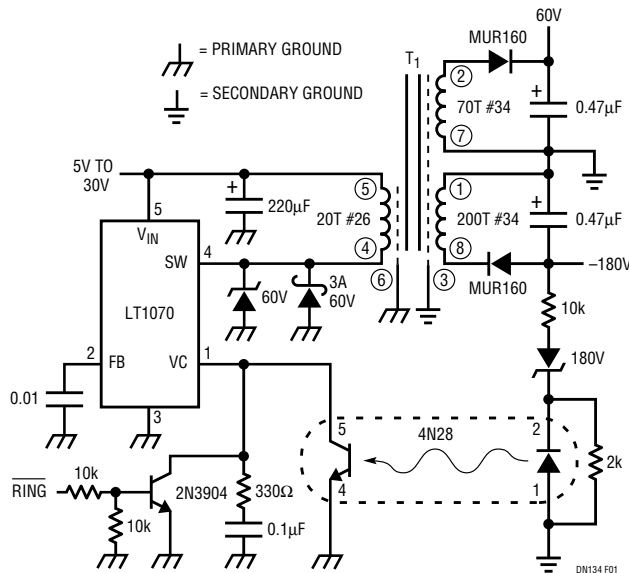

Figure 1. The Switching Power Supply

Quad Op Amp Rings Phones

When a phone rings, it rings with a cadence, a sequence of rings and pauses. The standard cadence is one second ringing followed by two seconds of silence. We use the first 1/4 of LT[®]1491 as a cadence oscillator, whose output is at V_{CC} for one second and then at V_{EE} for two seconds. This sequence repeats every three seconds, producing the all-too-familiar pattern. The actual ringing of the bell is done by a 20Hz AC sine wave signal at a signal level of 87V_{RMS} superimposed on -48VDC . The 20Hz signal is implemented with the second amplifier in the LT1491 which acts as a gated 20Hz oscillator (see Figure 3).

The third amplifier in the LT1491, which is configured as a lowpass filter, converts the square wave output of the oscillator to a sine wave by filtering out unwanted harmonics. Finally, the 87V_{RMS} and the -48VDC parts are handled by the fourth amplifier in the LT1491 and its steering of two external 15V regulators.

LT, LTC and LT are registered trademarks of Linear Technology Corporation.

MATERIALS	
2	EFD 20-15-3F8 Cores
1	EFD 20-15-8P Bobbin
2	EFD 20- Clip
2	0.007" Nomex Tape for Gap
Winding 1	Start Pin 1 200T #34
	Term Pin 8
	1 Wrap 0.002" Mylar Tape
Winding 2	Start Pin 2 70T #34
	Term Pin 7
	1 Wrap 0.002" Mylar Tape
Shields	Connect Pin 3 1T Foil Tape Faraday Shield
	1 Wrap 0.002" Mylar Tape
	Connect Pin 6 1T Foil Tape Faraday Shield
	1 Wrap 0.002" Mylar Tape
Winding 3	Start Pin 4 20T #26
	Term Pin 5
	Finish with Mylar Tape

Figure 2. Ring-Tone High Voltage Transformer Build Diagram

The rest of what we do, the part that is most difficult to follow, involves the output amplifier. In the output amplifier, the $6V_{P-P}$ signal from the waveform synthesizer is imposed across R12 (see Figure 4) into a virtual ground, creating a sine wave signal current. This current is added to the DC current flowing through R15 and the resulting current is imposed across R13. This stage amplifies the sine wave and offsets it to become an $87V_{RMS}$ sine wave imposed on a

$-48VDC$ bias. The trick here is that the voltage gain is in the $\pm 15V$ regulators, not the LT1491 which is merely steering currents.

This complete circuit (Figure 4) includes the ring-trip sense circuit to detect when the phone receiver is picked up. This circuit is fully protected for output shorts to any voltage within the power supply window of $-180V$ to $60V$.

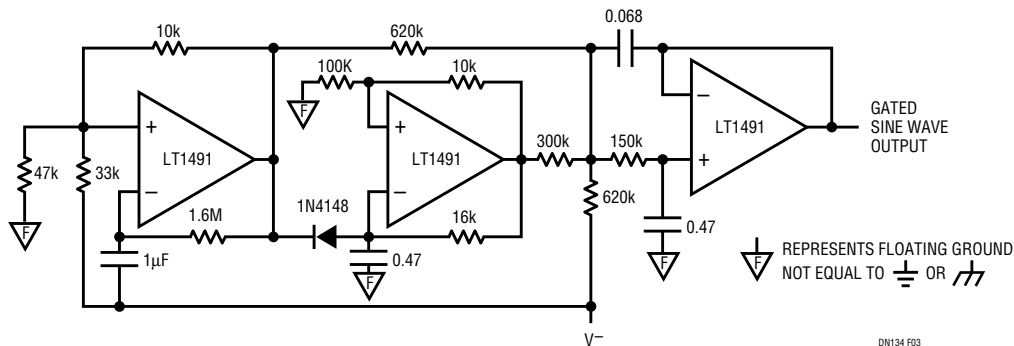

Figure 3. Wave Form Synthesizer

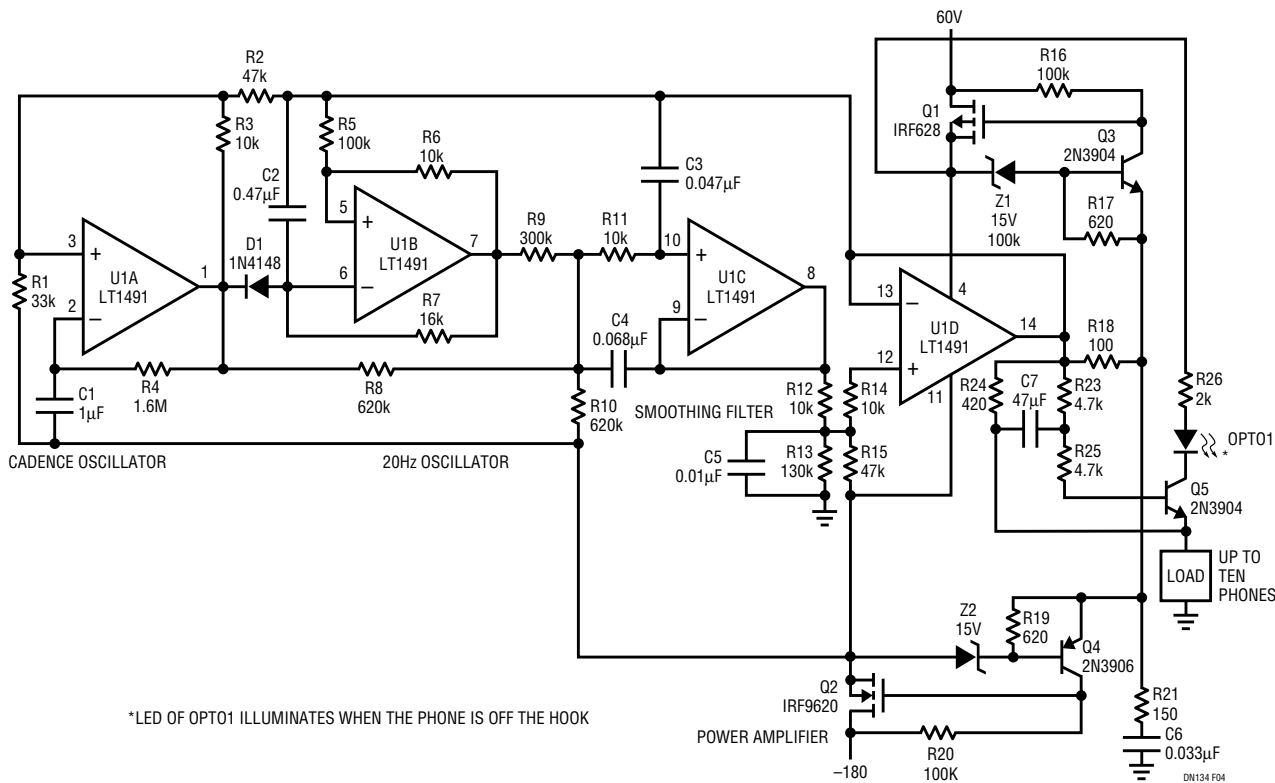

Figure 4. Complete Ring-Tone Generator Circuit

For literature on our Operational Amplifiers, call **1-800-4-LINEAR**. For applications help, call (408) 432-1900, Ext. 2593